



Type 3  
**NEW** SAFETY LASER SCANNER  
SD3-A1



JIS

# Smallest size in its class!\*

Monitor dangerous areas for unauthorized entry using flexible detection zones!

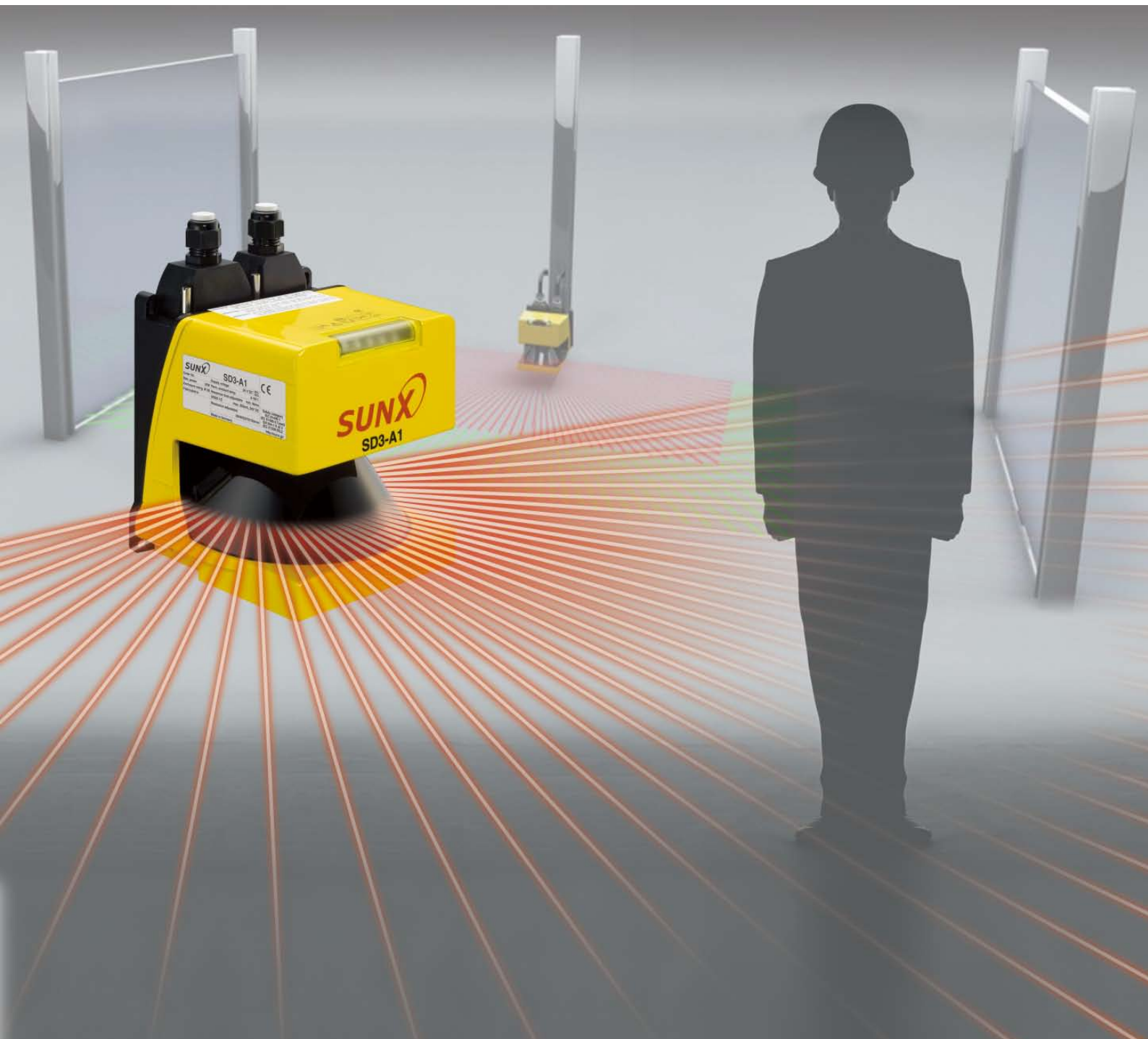

\* Based on research conducted by SUNX as of July 2008.

## APPLICATIONS

### Detecting entry into dangerous areas at processing machines



Warning and machine halt zones are implemented to detect workers in dangerous areas.

### Detecting presence in a defined field

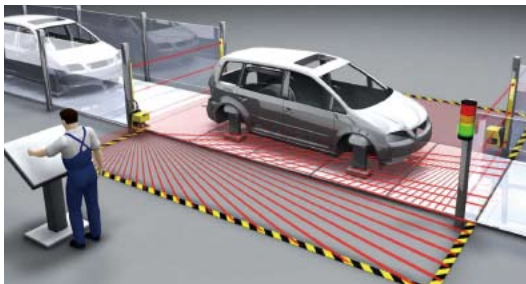

Install two safety laser scanners to build a detection zone that surrounds the monitoring object. Deactivation of detection is also possible by the flexible zone configuration.

### Guarding the sides on automatic guided vehicles

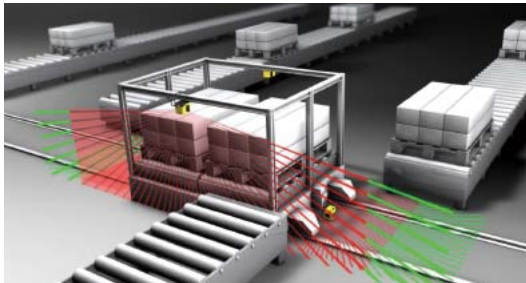

Injuries from a moving AGV can be prevented and fallen cargo can be monitored to avoid collisions.

### Confirming safety around automatic guided vehicles

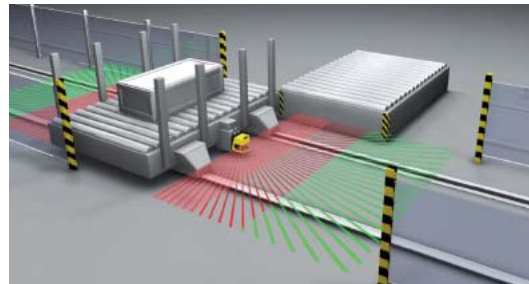

The scanner is used to slow down the speed of the vehicle upon detection at the warning zone and stop the vehicle upon entering the detection zone.

### Detecting entry into dangerous areas of circular cycle tables



One safety laser scanner can safeguard the front opening, where in the past two sets of light curtains were needed.

### Detecting entry into robot working areas

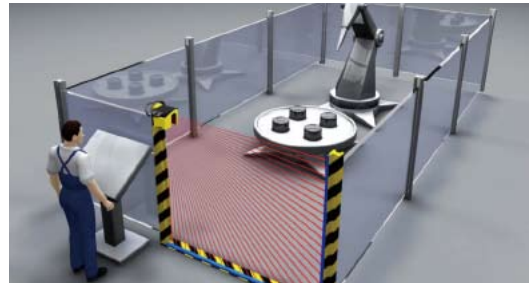

The scanner detects any entry of human body from the upper front opening. By activating the reference boundary function, beam misalignment can be monitored as the scanner is constantly detecting the pole across from it.

## Operating principle

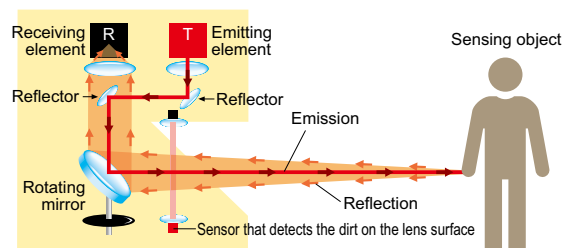
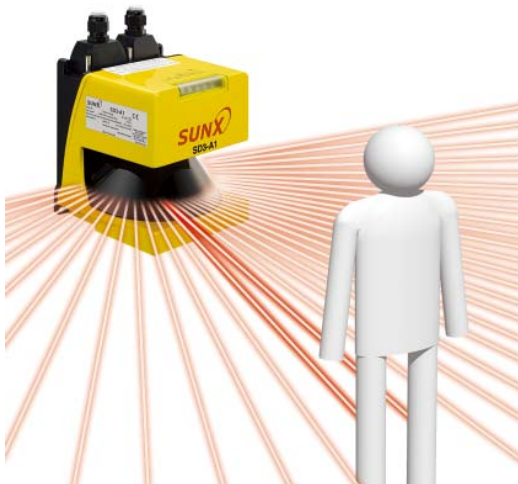

A pulsed laser beam is discharged from the emitting element (T) to the reflectors and onto a rotating mirror. The rotating mirror scans the laser as it rotates. The diffuse reflection from the sensing object is then returned to the receiving element (R) by means of the rotating mirror. The location of the sensing object is measured based on the travel time of the laser and the angular information of the rotating mirror. The monitoring area of max. 190° is divided into 528 segments (each 0.36°) by the rotating mirror.

## Freely configurable zones

Two zones can be widely monitored with the **SD3-A1**, the warning zone (within a radius 15 m **49.212 ft**) and the detection zone (protection zone) (within a radius 4 m **13.123 ft**). The contours of these zones are fully configurable for a perfect fit in every application. Up to eight zone patterns can be set and switched over at any given time, even during operation.

### Flexible zone configuration by PC

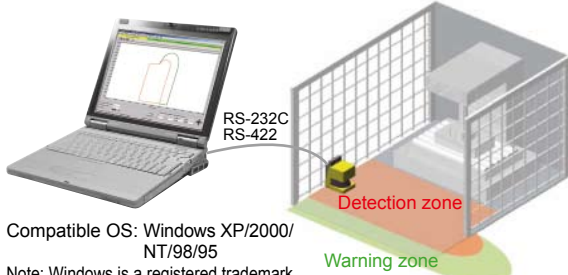

Compatible OS: Windows XP/2000/NT/98/95

Note: Windows is a registered trademark or trademark of Microsoft Corp. in the U.S. and/or other countries.

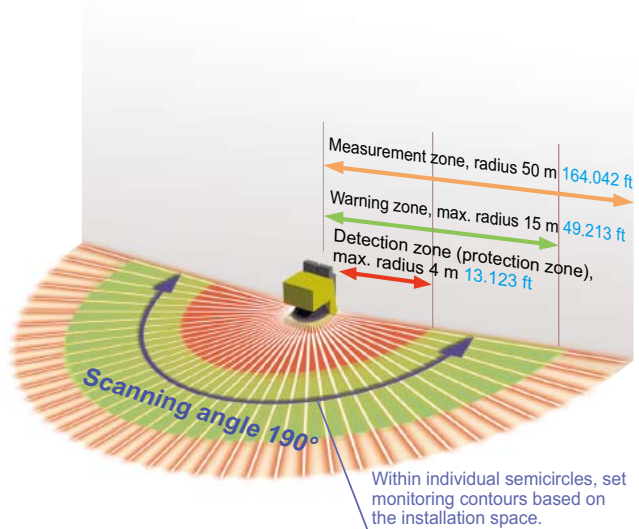

**Detection zone:** Instantly stops the machine upon intrusion (control output)

**Warning zone:** Releases warning upon intrusion (warning output)

### Up to 8 freely switchable zone patterns

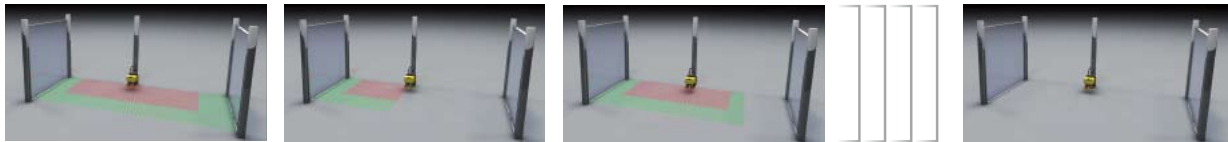

Zone No.1 (example)

Zone No.2 (example)

Zone No.3 (example) • • • No.7

Zone No.8 (fixed)  
Detection deactivated

## Smallest size in its class\*

W140 × H195 × D135 mm **W5.512 × H7.677 × D5.315 in**  
smallest in class.

\* In the class of detection zone 4 m 13.123 ft. Based on research conducted by SUNX as of July 2008.

**Smallest in class!**  
Volume is 27% less than conventional models

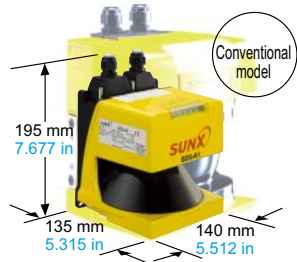

## Monitors beam misalignment after installation of safety laser scanner

By activating the reference boundary function which enables constant detection of stationary objects, the safety laser scanner memorizes the position of stationary objects, and monitors for beam misalignment after installation.

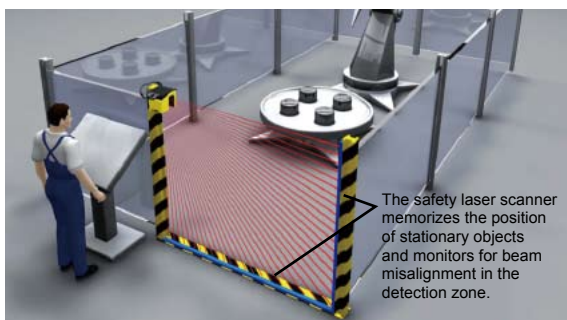

## Adjustment of response times enables interference prevention

The response time is adjustable within the range from 80 to 640 ms. When setting up multiple safety laser scanners in close vicinity, mutual interference can be prevented by adjusting the response time.

## Memorized configurations make post-maintenance recovery easy (Optional)

Configurations can be saved in the optional configuration plug which has a built-in memory. Even after maintenance or interchanging of safety laser scanners, the configurations from the memory in the plug can be easily loaded and recovered without the need to configure through a PC.



## SPECIFICATIONS

Item	Type	Safety laser scanner				
	Model No.	SD3-A1				
Applicable standards	International standards	IEC 61496-1/3 (Type 3), ISO 13849-1 (Category 3, PLd), IEC 61508-1 to 7 (SIL2), IEC 62061 (SIL2)				
	Japan	JIS B 9704-1/3 (Type 3), JIS B 9705-1 (Category 3), JIS C 0805 (SIL2)				
	Europe (EU)	EN 61496-1 (Type 3), ISO 13849-1 (Category 3, PLd), EN 61508-1 to 7 (SIL2)				
Detection zone	Min. sensing object setting	ø150 mm <b>ø5.906 in</b>	ø70 mm <b>ø2.756 in</b>	ø50 mm <b>ø1.969 in</b>	ø40 mm <b>ø1.575 in</b>	ø30mm <b>ø1.181 in</b>
	Sensing range (radius)	0 to 4.0 m <b>0 to 13.123 ft</b>	0 to 4.0 m <b>0 to 13.123 ft</b>	0 to 2.8 m <b>0 to 9.186 ft</b>	0 to 2.2 m <b>0 to 7.218 ft</b>	0 to 1.6m <b>0 to 5.249 ft</b>
	Sensing object reflectance	Minimum 1.8 %				
Warning zone	Min. sensing object setting	ø150 mm <b>ø5.906 in</b> (fixed)				
	Sensing range (radius)	0 to 15 m <b>0 to 49.213 ft</b>				
	Sensing object reflectance	Minimum 20 %				
Measurement zone	Max. measurement range (radius)	50 m <b>164.042 ft</b> (fixed)				
Scanning angle		190° / 180° (by setting)				
Number of zone setting		Max. 7 + 1 (without detection zone) [Zone pairs in combination of detection zone and warning zone can be switched over by external input]				
Min. zone setting range		200 mm <b>7.874 in</b>				
Supply voltage (U <sub>s</sub> )		24 V DC $^{+20}_{-30}$ % (IEC 60742)				
Current consumption		300 mA approx. (excluding external connection load)				
Fuse (power supply)		1.25 A semi-time-lag fuse				
Control outputs (OSSD 1, OSSD 2)		PNP open-collector transistor 2 outputs • Rated operating voltage: supply voltage (U <sub>s</sub> ) – 3.2 V • Max. source current: 250 mA • Residual voltage: 3.2 V or less				
	Operation mode	When no object enters into the detection zone: ON, When an object enters: OFF				
	Response time	Min. 80 ms (2 scans) to max. 640 ms (16 scans) switching method				
	Protection circuit	Incorporated				
Warning output 1 (Alarm 1)		PNP open-collector transistor • Rated operating voltage: supply voltage (U <sub>s</sub> ) – 4 V • Max. source current: 100 mA • Residual voltage: 4 V or less				
	Operation mode	Switching method of operation mode (set by below) • Not used • Main unit at normal operation: ON, Abnormal operation: OFF • When no object enters into the warning zone: ON, When an object enters: OFF • Main unit at normal operation: ON, Abnormal operation: OFF and When no object enters into the warning zone: ON, When an object enters: OFF				
	Response time	Min. 80 ms (2 scans) to max. 640 ms (16 scans) switching method				
Warning output 2 (Alarm 2)		PNP open-collector transistor • Rated operating voltage: supply voltage (U <sub>s</sub> ) – 4 V • Max. source current: 100 mA • Residual voltage: 4 V or less				
	Operation mode	Main unit at normal operation: ON, Abnormal operation: OFF				
Laser protection class		Class 1 (IEC 60825)				
Peak emission wavelength		905 nm <b>0.036 mil</b>				
Environmental resistance	Degree of protection	IP65				
	Ambient temperature	0 to +50 °C <b>+32 to +122 °F</b> , Storage: –20 to + 60 °C <b>–4 to +140 °F</b>				
	Ambient humidity	Operation and storage: Max. 95 % RH (No dew condensation)				
	Vibration resistance / Shock resistance	10 to 150 Hz frequency, 5 G max. (50 m/s <sup>2</sup> approx.) in X, Y and Z directions for twenty times each				
Maximum cable length		15-pin plug: Max. 50 m <b>164.042 ft</b> , 9-pin plug: Max. 10 m <b>32.808 ft</b> (when using RS-232C) / Max. 50 m <b>164.042 ft</b> (when using RS-422) (by using optional connection cable) (Note)				
Material		Main body: Die-cast aluminum, Scanner window: Thermoplastic resin				
Accessories		<b>SD3-PS</b> (exclusive 15-pin connector): 1 pc., <b>SD3-RS232</b> (exclusive 9-pin connector): 1 pc., Mounting screws [M5 (length 20 mm <b>0.787 in</b> ) hexagon-socket-head bolt: 2 pcs., M5 (length 16 mm <b>0.630 in</b> ) hexagon-socket-head bolt: 2 pcs., attached to <b>SD3-PS</b> ]: 1 set, Simplified instruction manual: 1 copy, Installation CD-ROM (includes detailed instruction manual data): 1 CD				
Weight		Net weight: 2.1 kg approx., Gross weight: 2.9 kg approx.				

Note: Be careful that a voltage drop may occur depending on the cable length or cable's conductor cross-section area.

**OPTIONS**

Designation		Model No.	Description	
Mounting bracket		<b>MS-SD3-1</b>	Used to mount the safety laser scanner in rear direction. Net weight: 530 g approx.	
15-pin connector side	Rear elbow connector	<b>SD3-PS-L</b>	Exclusive 15-pin connector. Rear elbow type. For soldering. Net weight: 35 g approx.	
	Configuration plug	<b>SD3-CP</b>	15-pin connector with built-in memory that saves setting information. For soldering. Net weight: 35 g approx.	
	Configuration plug attached cable	<b>SD3-CP-C5</b>	Cable length: 5 m <b>16.404 ft</b> Net weight: 690 g approx. (1 cable)	Cable with configuration plug. Min. bending radius: R50 mm <b>R1.969 in</b>
		<b>SD3-CP-C10</b>	Cable length: 10 m <b>32.808 ft</b> Net weight: 1.3 kg approx. (1 cable)	
		<b>SD3-CP-C25</b>	Cable length: 25 m <b>82.021 ft</b> Net weight: 3.3 kg approx. (1 cable)	
		<b>SD3-CP-C50</b>	Cable length: 50 m <b>164.042 ft</b> Net weight: 6.3 kg approx. (1 cable)	
<b>SD3-CP-C10-L</b>		Cable length: 10 m <b>32.808 ft</b> Elbow type Net weight: 1.3 kg approx. (1 cable)		
9-pin connector side	Rear elbow connector	<b>SD3-RS232-L</b>	Exclusive 9-pin connector used when PC is not connected. Rear elbow type. Cable soldering is possible. Net weight: 30 g approx.	
	PC connection cable	<b>SD3-RS232-C3</b>	Cable length: 3 m <b>9.843 ft</b> Net weight: 160 g approx. (1 cable)	Exclusive 9-pin connector for RS-232C/422 with PC cable. Min. bending radius: R50 mm <b>R1.969 in</b>
		<b>SD3-RS232-C5</b>	Cable length: 5 m <b>16.404 ft</b> Net weight: 230 g approx. (1 cable)	
		<b>SD3-RS232-C10</b>	Cable length: 10 m <b>32.808 ft</b> Net weight: 400 g approx. (1 cable)	
Operation checking tool	<b>SD3-DEMO-24V</b>	Configuration and test device for safety laser scanner. Supply voltage: 24 V DC, Net weight: 270 g approx.		
Cleaning set	<b>SD3-CLEAN1</b>	Used to clean scanner window (lens surface). Cleaning fluid 150 ml, cleaning cloth 25 sheets.		
	<b>SD3-CLEAN2</b>	Used to clean scanner window (lens surface). Cleaning fluid 1 l, cleaning cloth 100 sheets.		

**Mounting bracket**

- **MS-SD3-1**



Two M8 (length 45 mm **1.772 in**) hexagon-socket-head bolts, two plain washers for M8, two M5 (length 20 mm **0.787 in**) hexagon-socket-head bolts, two M5 (length 16 mm **0.630 in**) hexagon-socket-head bolts, and four plain washers for M5 are attached.

**Operation checking tool**

- **SD3-DEMO-24V**



One exclusive connection cable is attached.

**Rear elbow connector**

- **SD3-PS-L**



Two M5 (length 20 mm **0.787 in**) hexagon-socket-head bolts, two M5 (length 16 mm **0.630 in**) hexagon-socket-head bolts, and two cylindrical nuts are attached.

**Configuration plug**

- **SD3-CP**



Two cylindrical nuts are attached.

**Configuration plug attached cable**

- **SD3-CP-C□**
- **SD3-CP-C10-L**



**Rear elbow connector**

- **SD3-RS232-L**



Two cylindrical nuts are attached.

**PC connection cable**

- **SD3-RS232-C□**



**Cleaning set**

- **SD3-CLEAN1**
- **SD3-CLEAN2**



**Spare parts (Accessories for safety laser scanner)**

Designation	Model No.	Description
Straight connector for 15-pin connector side	<b>SD3-PS</b>	Exclusive 15-pin connector. Straight type. For soldering. Net weight: 35 g approx.
Straight connector for 9-pin connector side	<b>SD3-RS232</b>	Exclusive 9-pin connector. Straight type. For soldering. Net weight: 30 g approx.
Scanner window	<b>SD3-WINDOW</b>	Replacement lens for safety laser scanner body. Net weight: 45 g approx.

**Straight connector for 15-pin connector side**

- **SD3-PS**



Two M5 (length 20 mm **0.787 in**) hexagon-socket-head bolts, two M5 (length 16 mm **0.630 in**) hexagon-socket-head bolts, and two cylindrical nuts are attached.

**Straight connector for 9-pin connector side**

- **SD3-RS232**



Two cylindrical nuts are attached.

**Scanner window**

- **SD3-WINDOW**



## I/O CIRCUIT AND WIRING DIAGRAMS

### Connection wiring example with control unit SF-C13

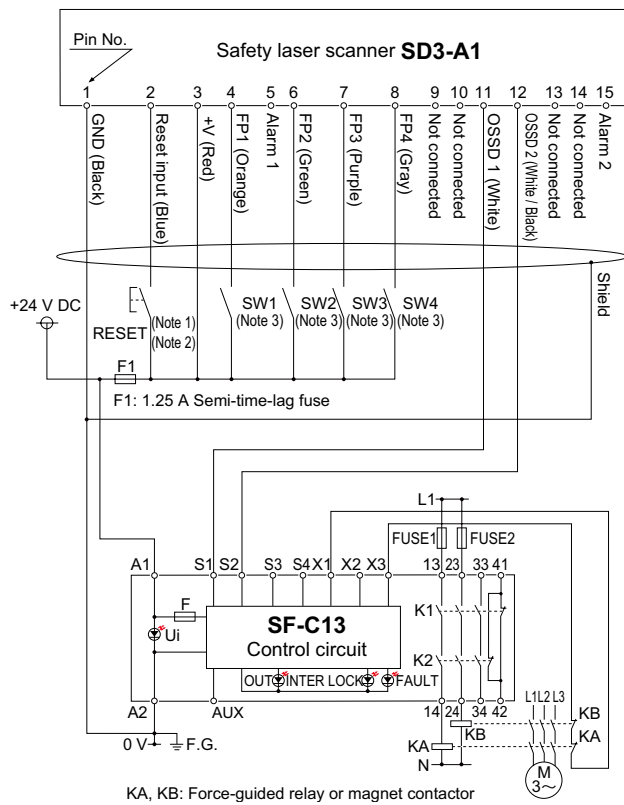

- Notes: 1) The above diagram is when using manual reset. If automatic reset is used, a reset (RESET) button is not needed. Settings by software are needed separately.  
2) Use a momentary-type switch as the reset (RESET) button.  
3) For zone-control inputs (SW1 to 4), use PLC etc. (input time should be 40 ms or less).

Zone No.	Control inputs			
	FP1	FP2	FP3	FP4
1	1	0	0	0
2	0	1	0	0
3	0	0	1	0
4	0	0	0	1
5	1	1	1	0
6	1	1	0	1
7	1	0	1	1
8	0	1	1	1

## DIMENSIONS (Unit: mm in)

The CAD data in the dimensions can be downloaded from the SUNX website: <http://www.sunx.com>

### SD3-A1

Safety laser scanner

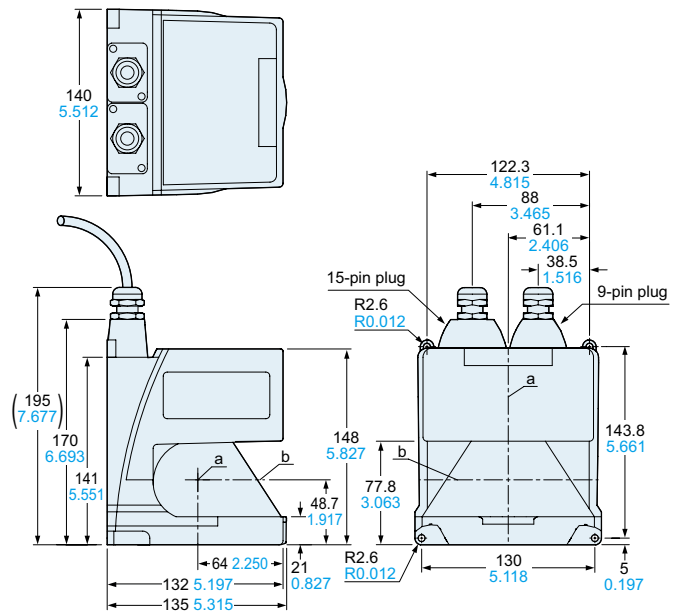

### MS-SD3-1

Mounting bracket (Optional)

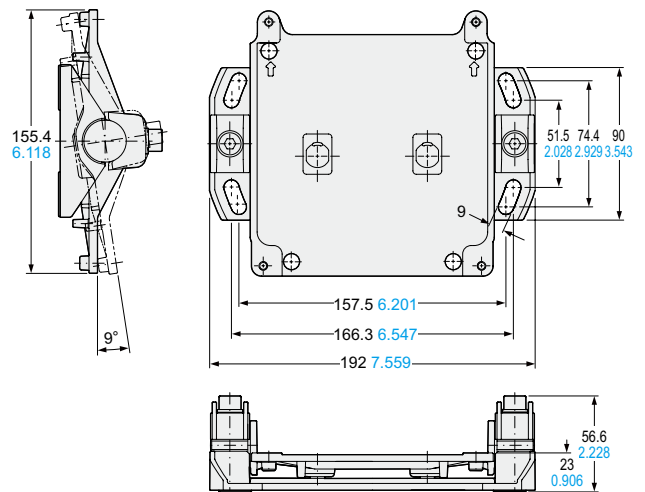

Material: Aluminum  
Net weight: 530 g approx.

All information is subject to change without prior notice.



<http://www.sunx.com>

### SUNX Limited

2431-1 Ushiyama-cho, Kasugai-shi, Aichi,  
486-0901, Japan  
Phone: +81-568-33-7211  
FAX: +81-568-33-2631

### Overseas Sales Division

Phone: +81-568-33-7861  
FAX: +81-568-33-8591

Printed on recycled paper PRINTED IN JAPAN

No.CE-SD3-3 September, 2008